

Mineral Insulated Thermocouple model 8(2GoH)

MIT with protection shell model 8(2GoH) according or similar to DIN 43722

In general

The temperature sensors manufactured by Reckmann GmbH (R58®) are solely intended for the measurement of process temperatures in solid, liquid and gaseous media. 2G/2GoH This model allow a directly screw in into the process connection of a autoclave or pipeline.

Areas of application:

Autoclaves, machine and plant construction, food and chemical industry, energy and power plant technology, building materials industry, recycling, pipeline construction.

For installation-specific data, see installation instructions
Type code 1R9-B1.

Technical datas

- **Connection head** (fig. 1/1) according to DIN EN 50446, Preferred heads: Form B, B-KL, B-KS, BA-KL, BA-KS, BA-KLH, BA-KSH, B-VA, B-GR, B-KU, B-KUKL, B-KUHKL, IP 54. Dimensions see page 2.
- **On request:** IP 65 or IP 67.
- **Protection shell** (fig. 1/3 to 4) according to or similar to DIN 43772. Standard material 1.4571. Preferred diameter 9 mm.
- **Process connection** (fig. 1/3) via double nipple screwed into the head with all common threads. Standard thread G1/2".
- **Measuring insert** (fig. 1/2) exchangeable, according to or similar to DIN 43735. Sensor depending on application: with 1 or 2 thermocouples according to IEC / EN 60584-1. Recommended application temperature depending on thermocouple type and diameter:
 - Type K: Ø 3.0 mm up to 1070 °C, 6.0 and 8.0 mm up to 1100 °C.
 - Type J: Ø 3.0 mm up to 520 °C, 6.0 and 8.0 mm up to 720 °C.
 - Type N: Ø 3.0 mm up to 1070 °C, 6.0 and 8.0 mm up to 1100 °C.
 - Type E: Ø 3.0 mm up to 650 °C, 6.0 and 8.0 mm up to 820 °C.
 - Type T: Ø 3.0 mm up to 315 °C, 6.0 and 8.0 mm up to 350 °C.**Note:** Use only at non-critical process temperatures (< 400 °C), as the temperature decoupling is only effected via the double nipple.
- **Sheath material** Design according to IEC / EN 61515. Preferred material 2.4816. Preferred diameter 3 or 6 mm.
- **Optional:** Class 3 requirements (-200 °C to 40 °C) on request. For requirements of class 1 and class 3 only possible with specially selected sheath material, high expense and not with type T.

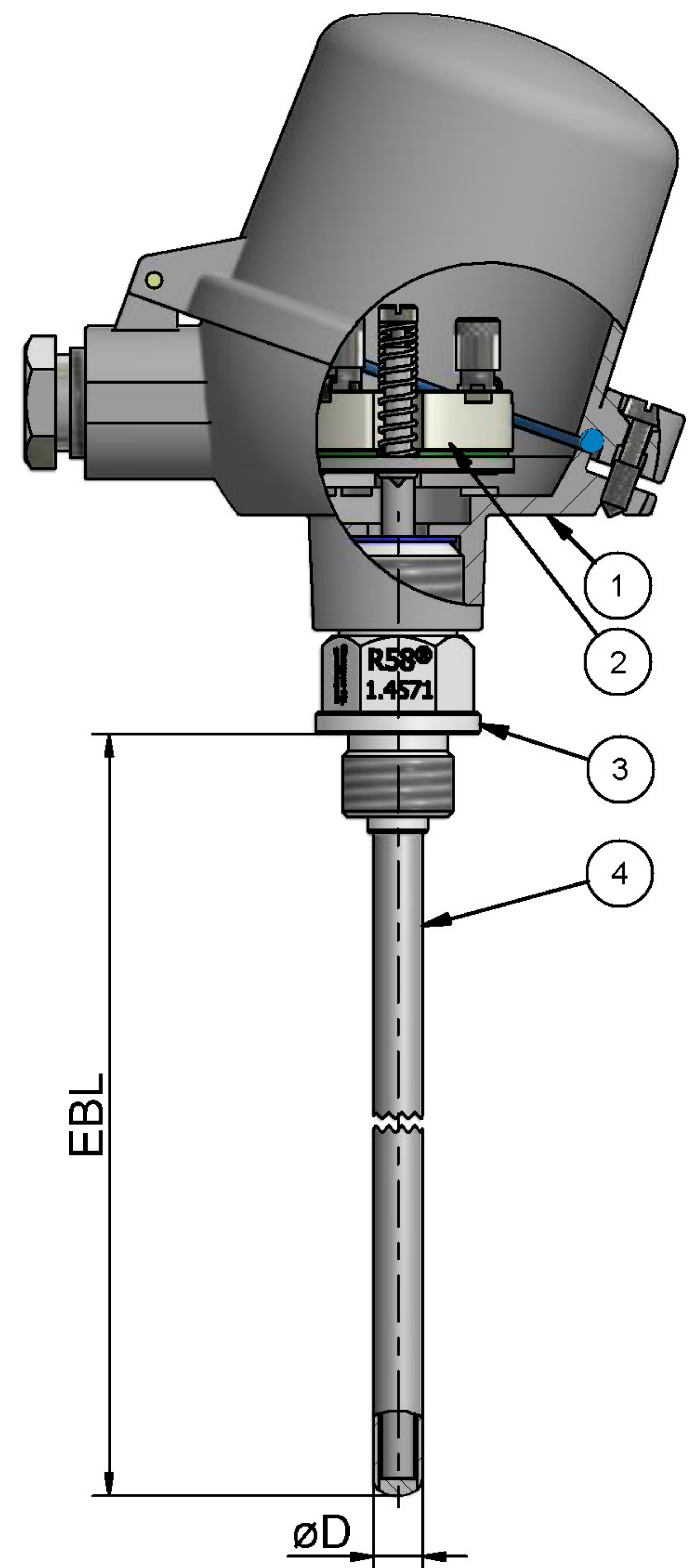
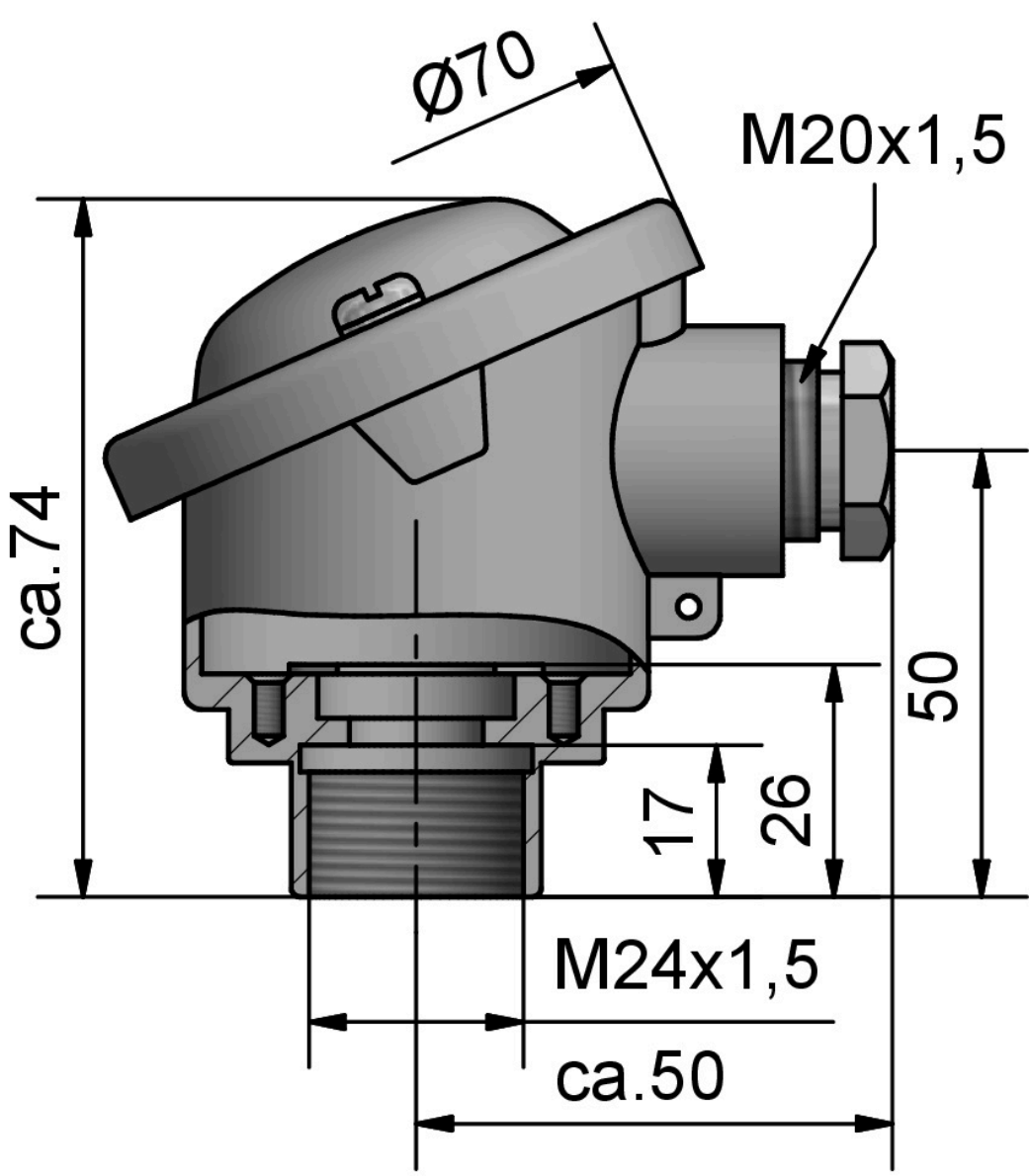

fig. 1

Optional connection heads / connection diagrams

As an alternative to the cable gland, an M12 flush-type connector is possible.



head model B
M24 x 1,5

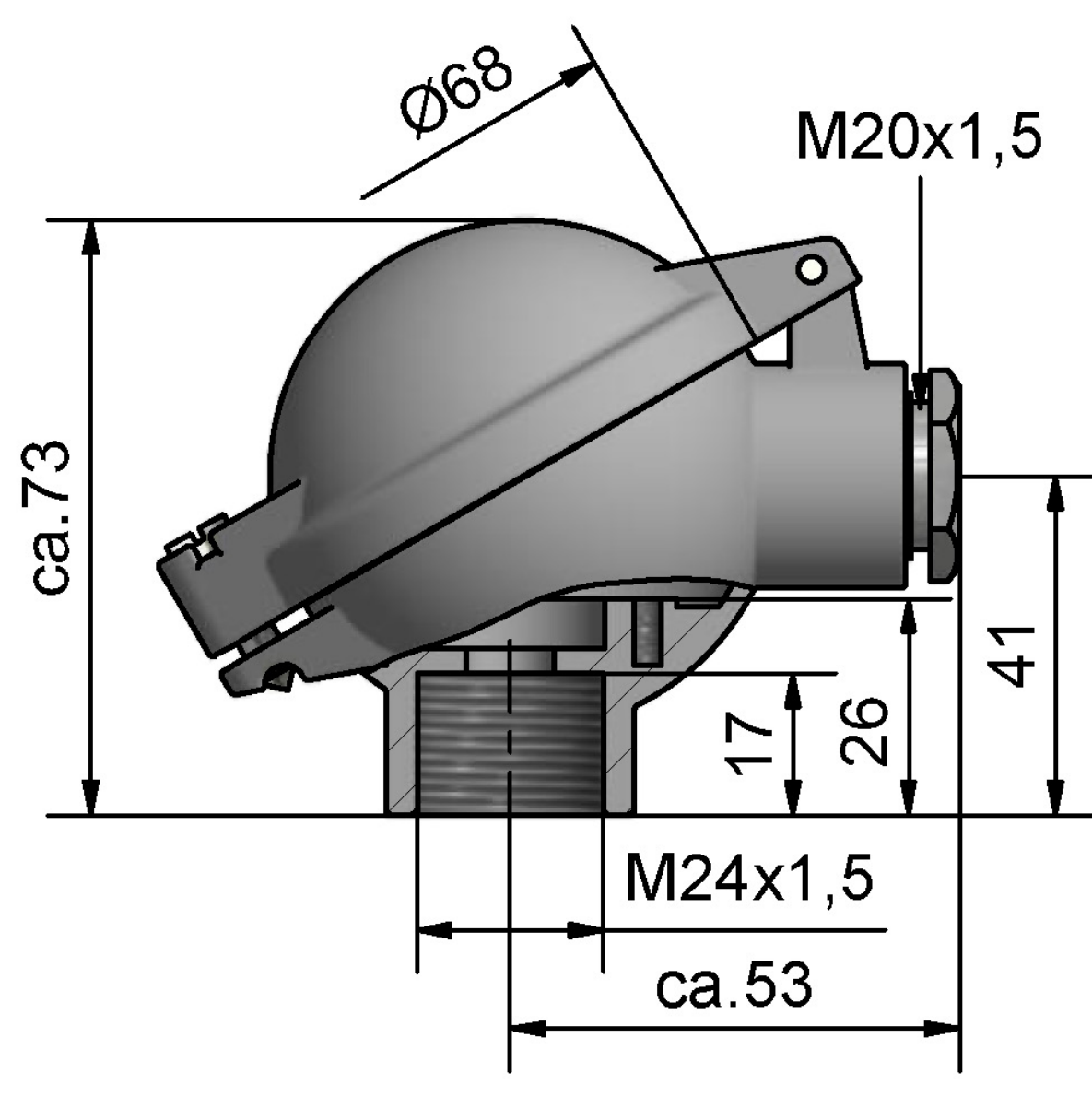

head model B-KL
M24 x 1,5

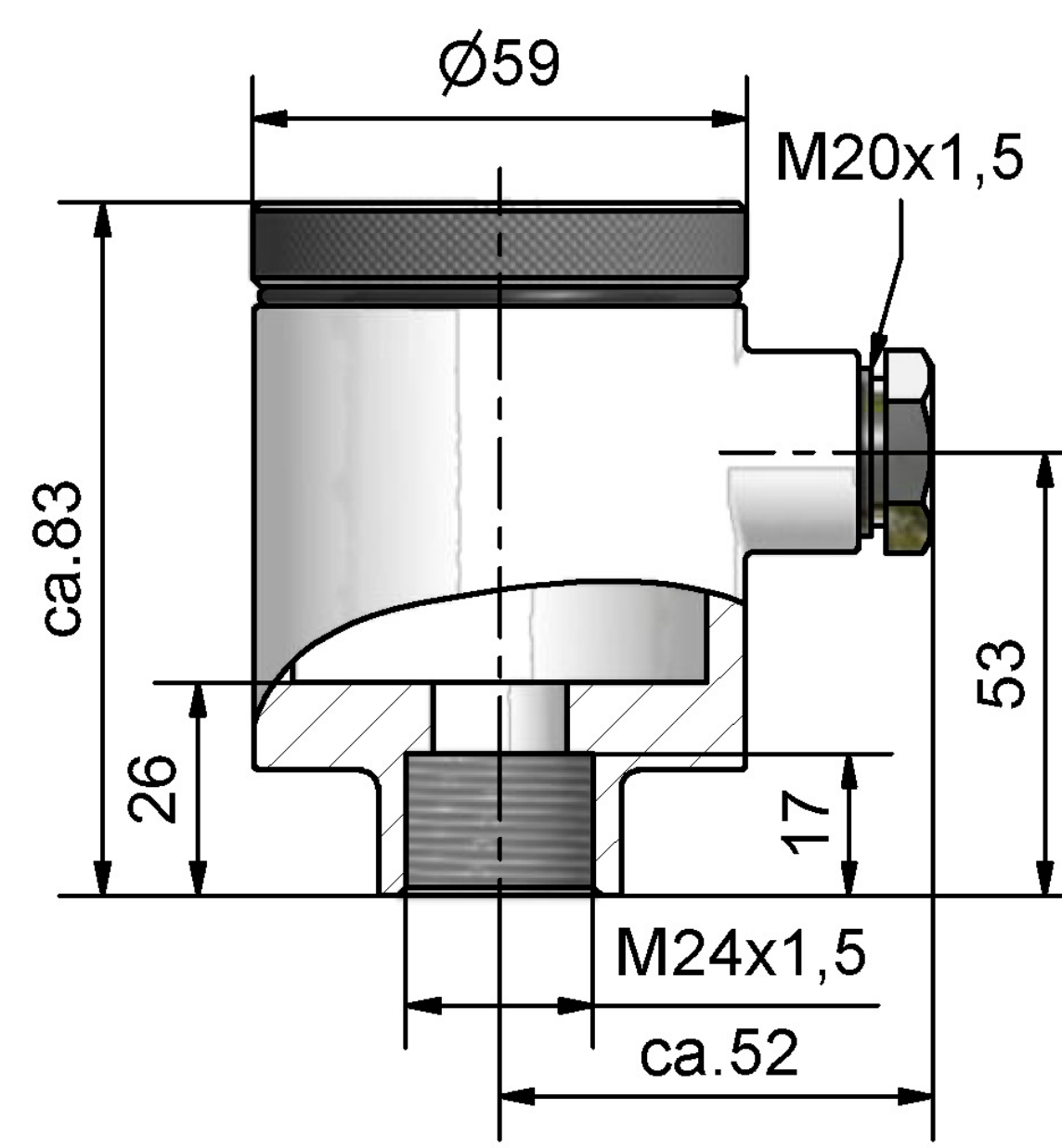

head model B-VA
M24 x 1,5

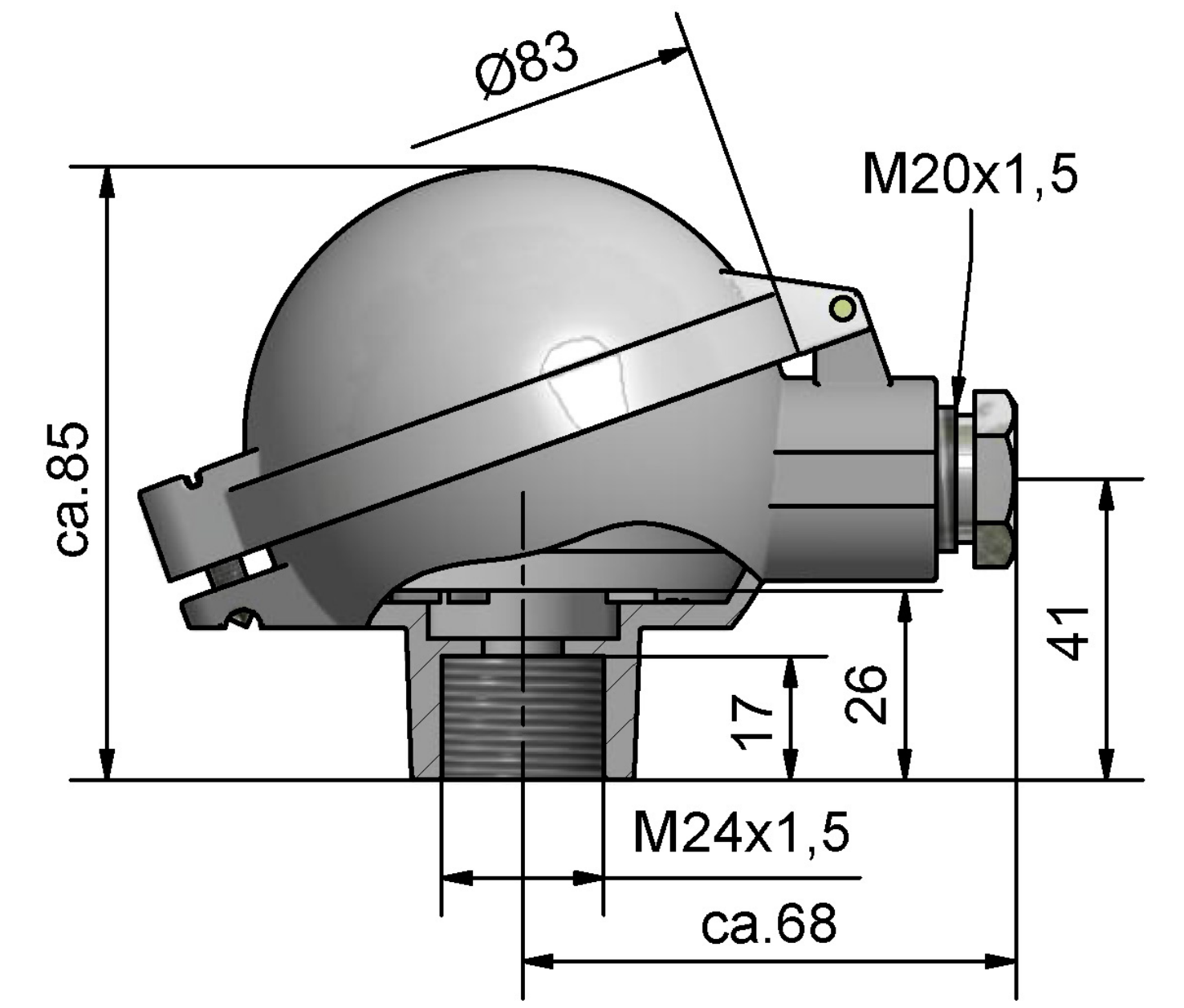

head model BA-KL
M24 x 1,5

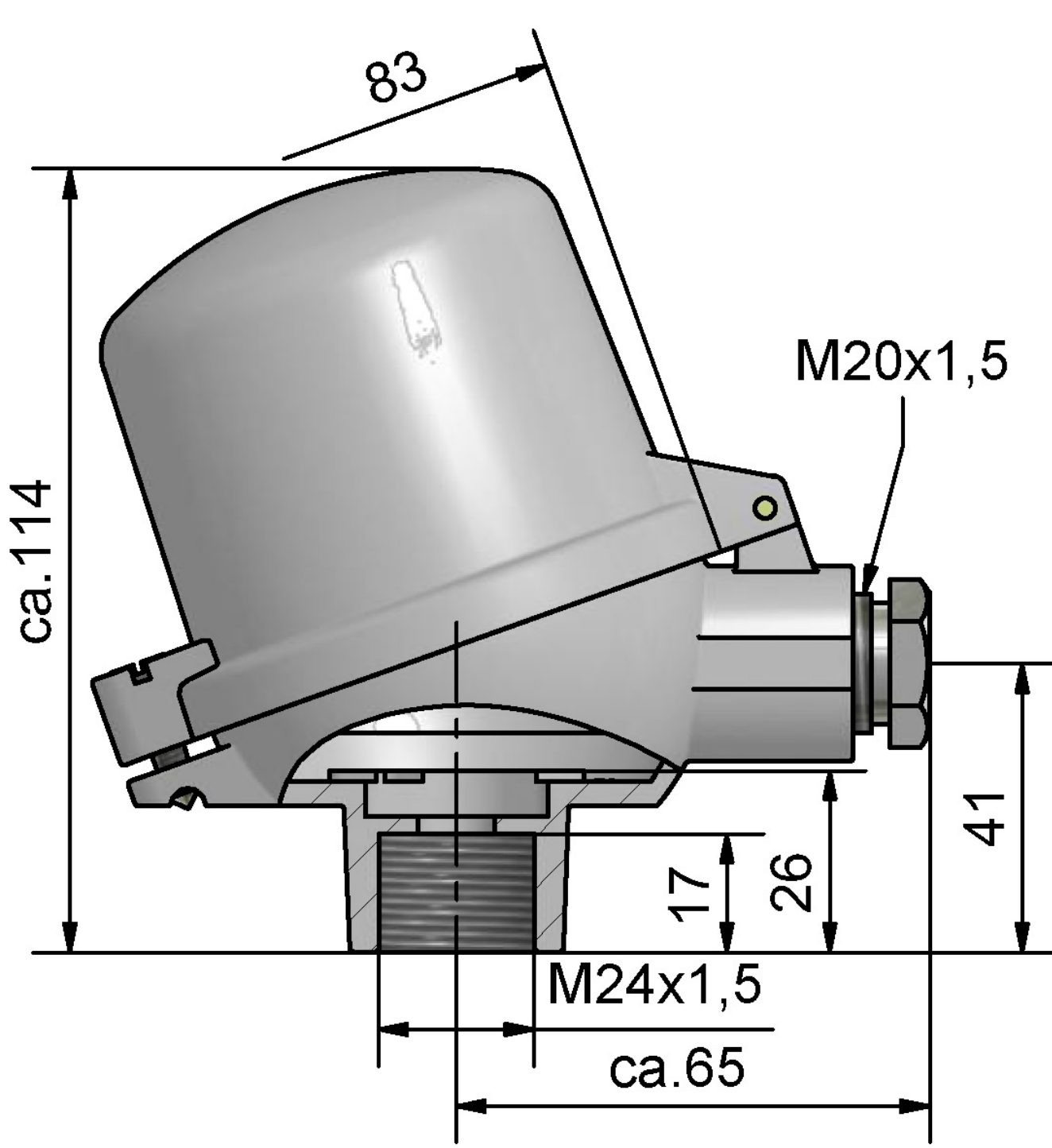

head model BA-KLH
M24 x 1,5

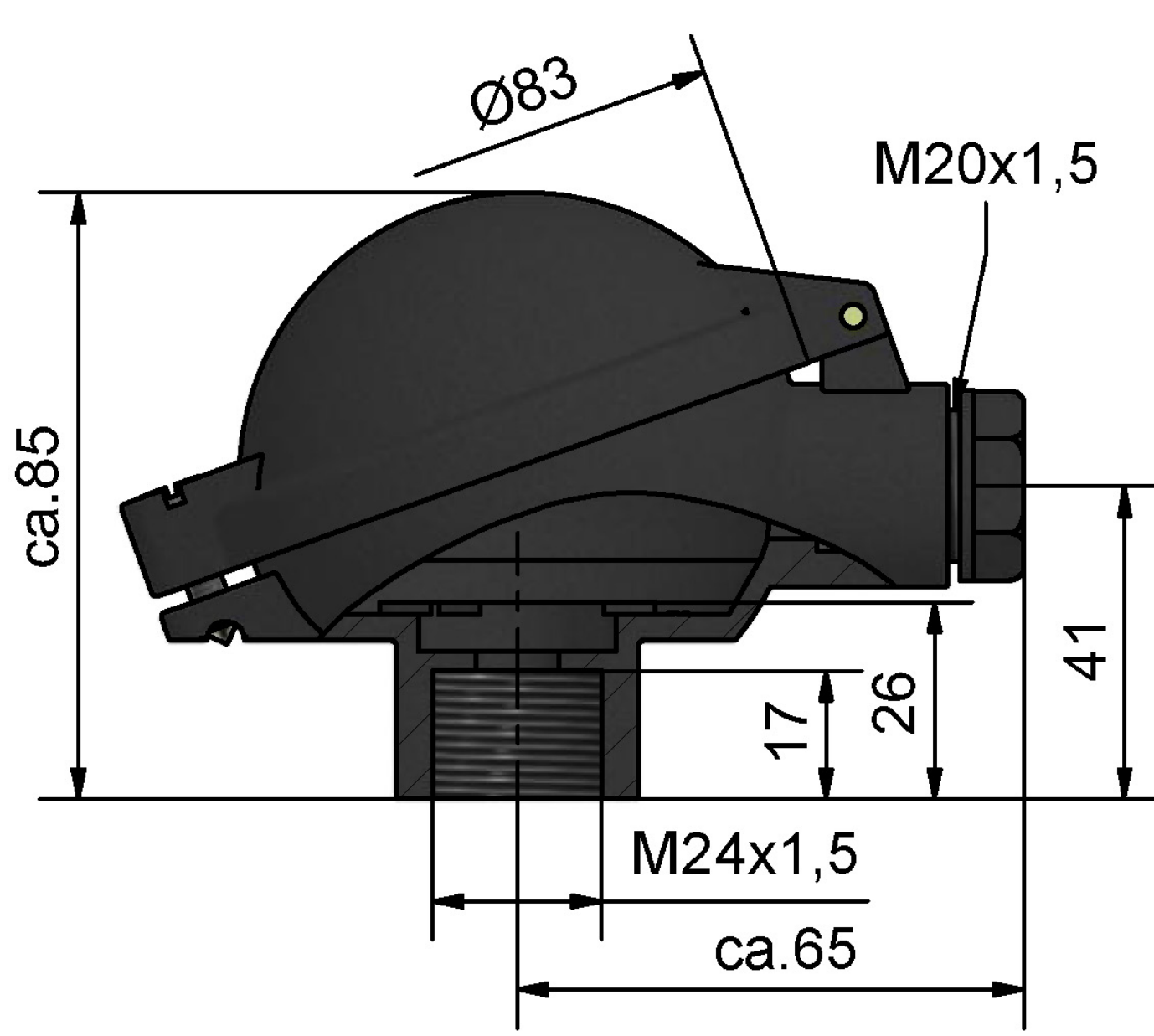

head model B-KUKL
M24 x 1,5

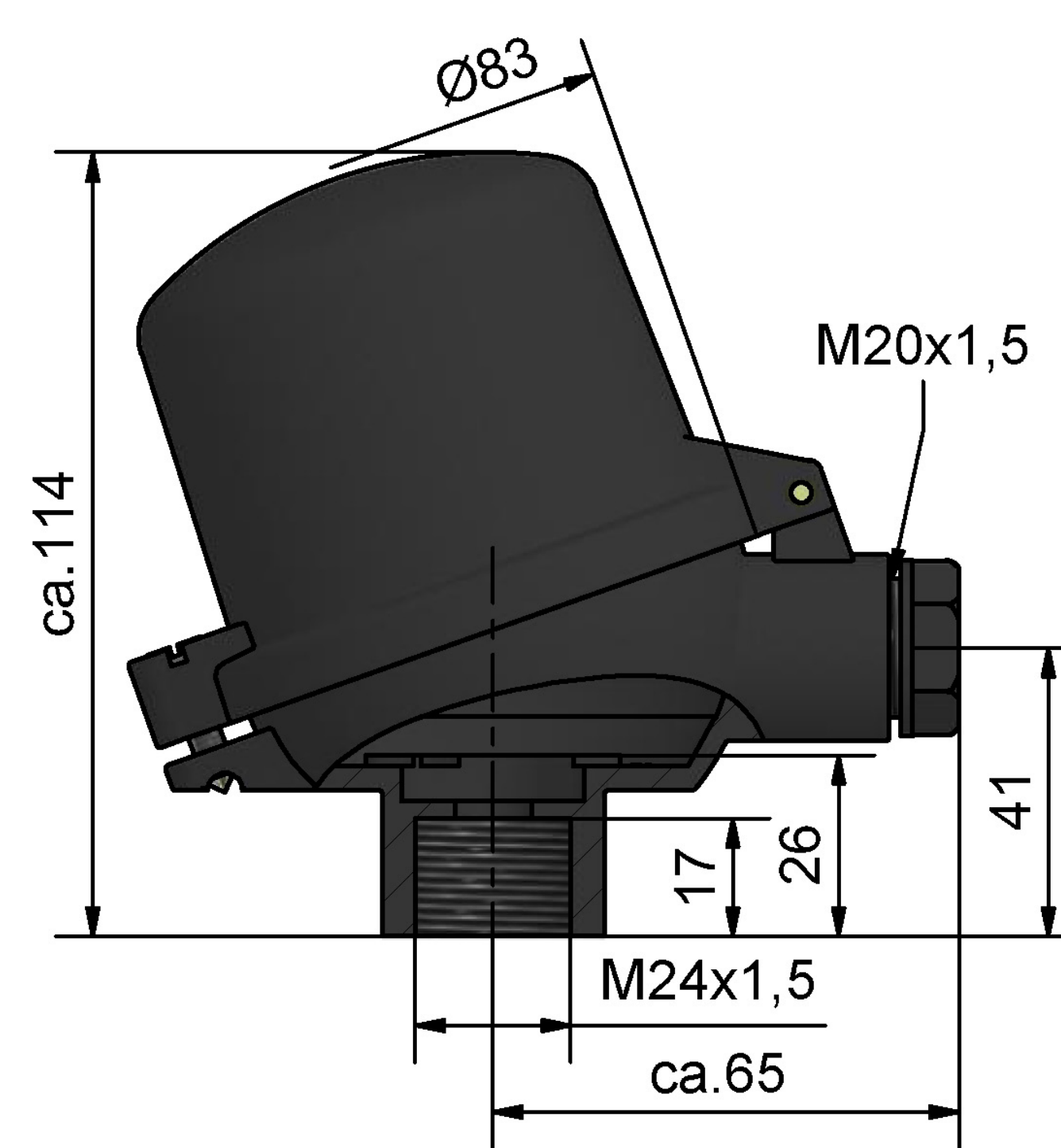

head model B-KUHKL
M24 x 1,5

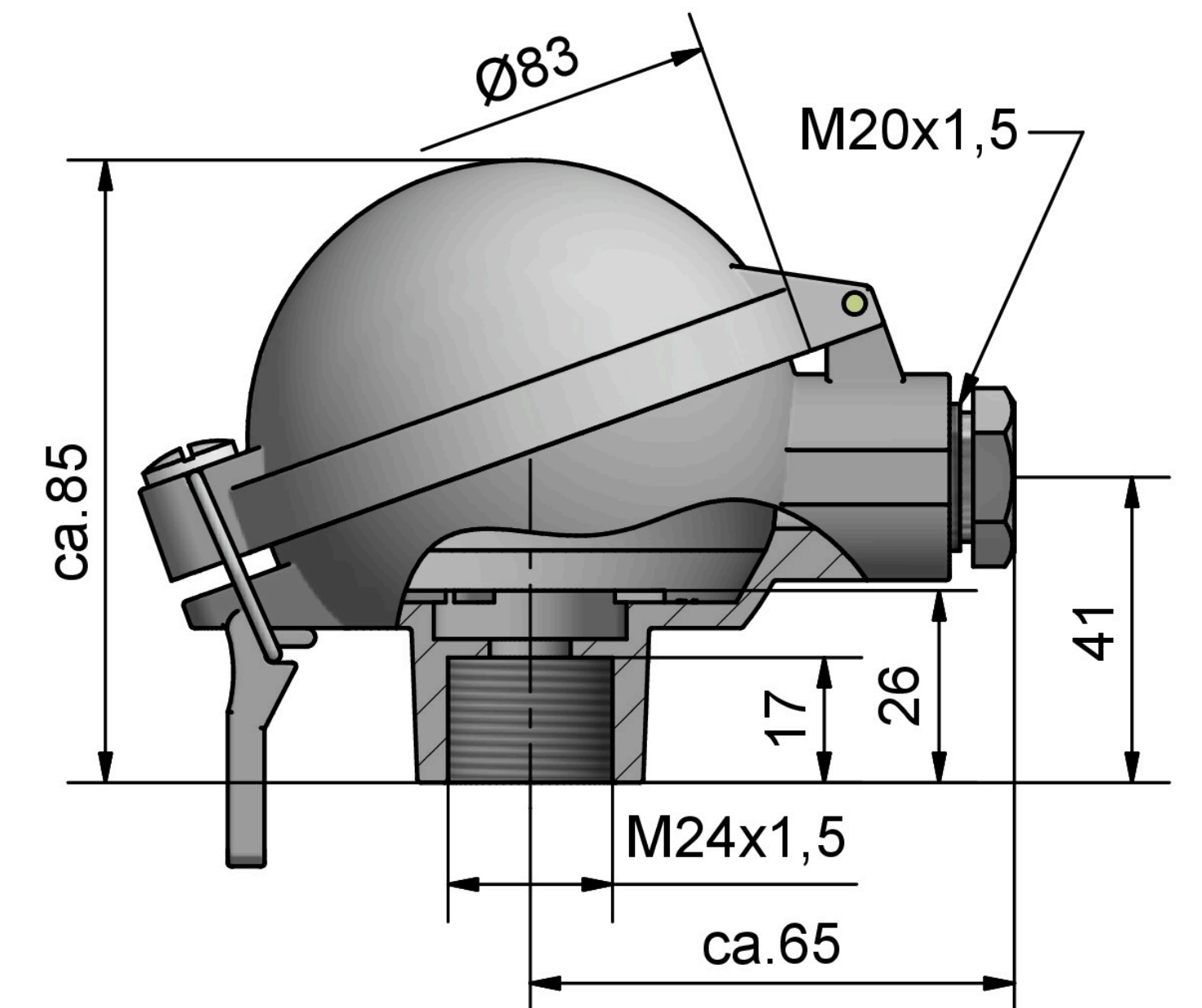

head model BA-KS
M24 x 1,5

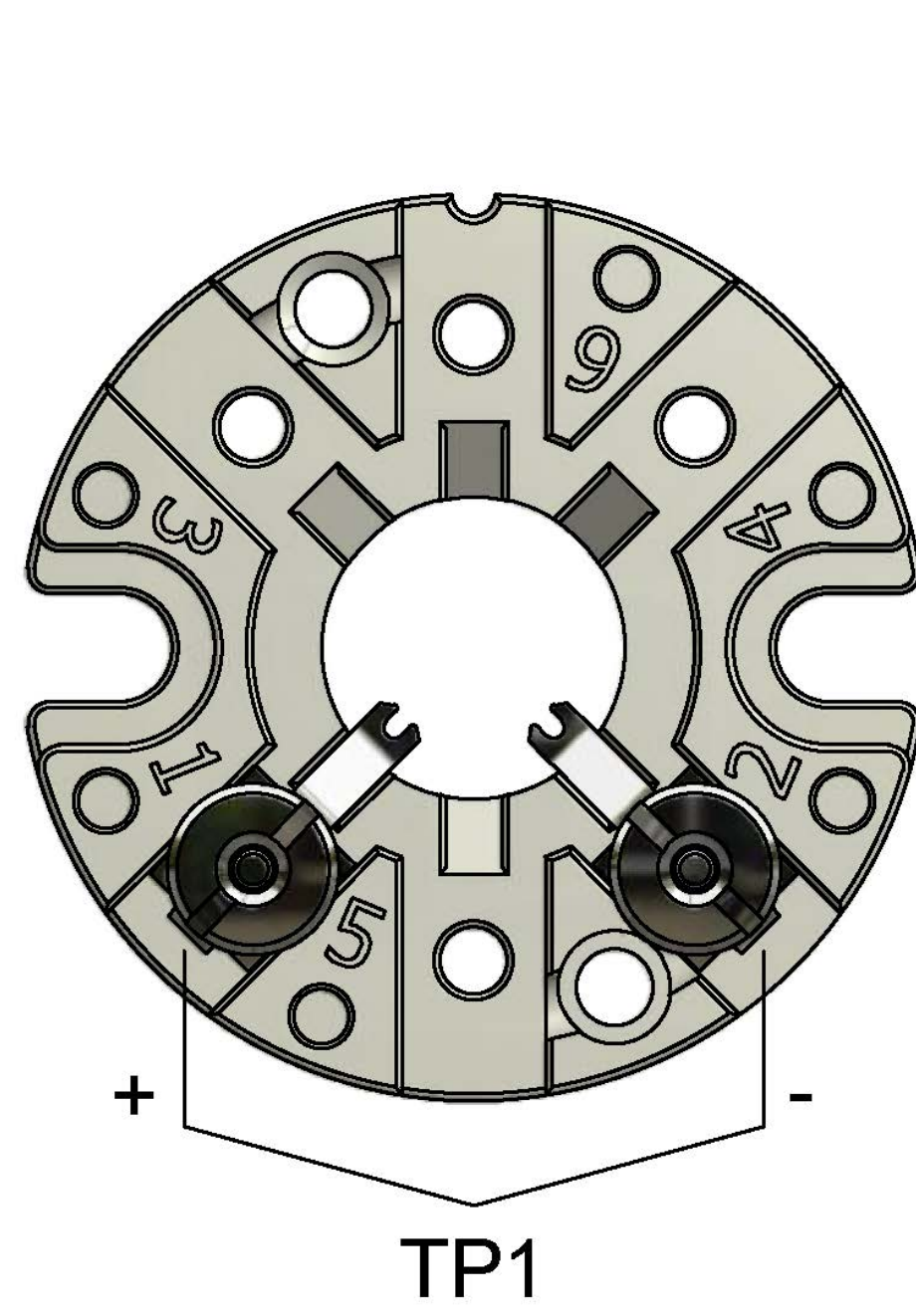

Terminal base model B
1 thermocouple

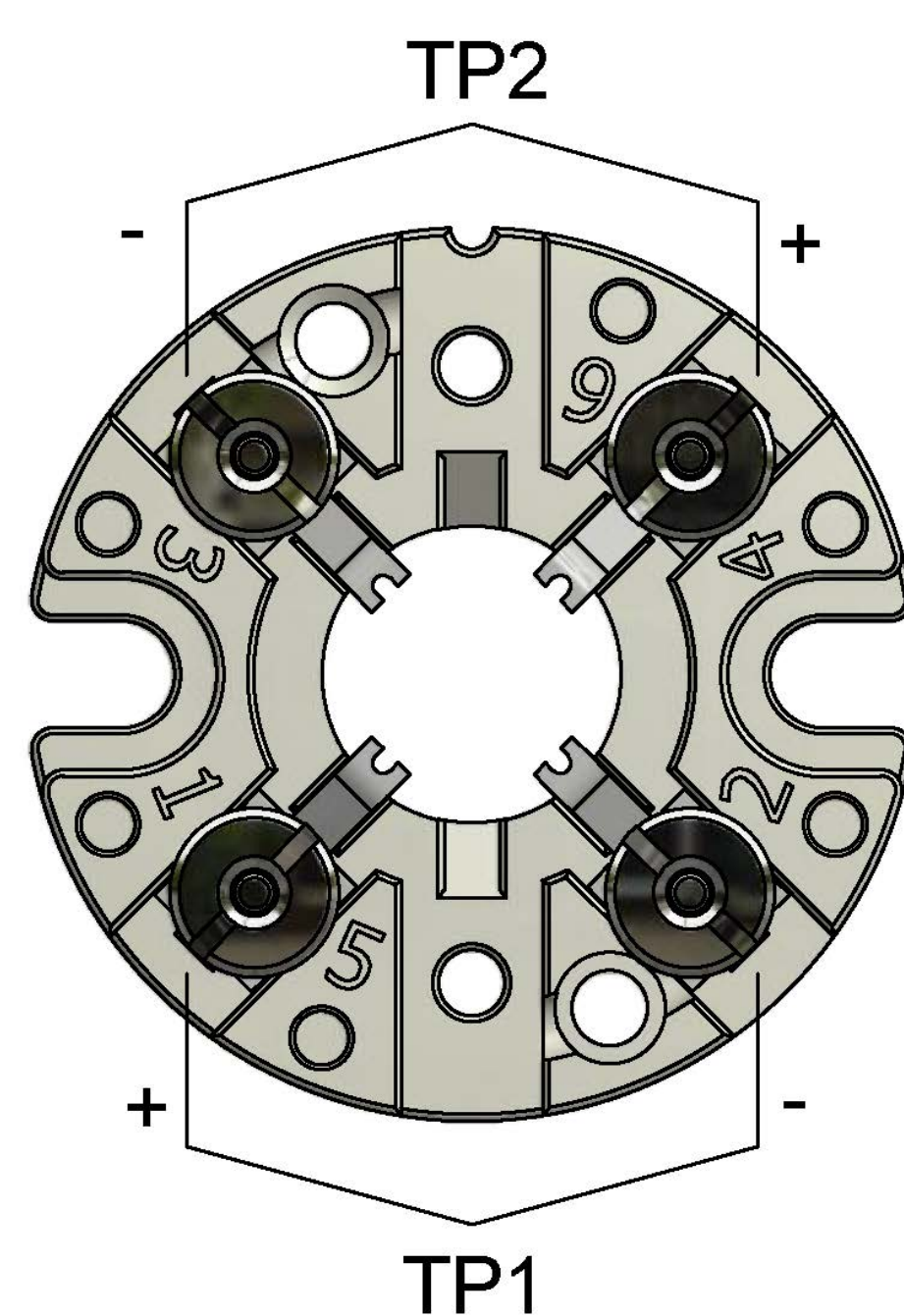

Terminal base model B
2 thermocouples

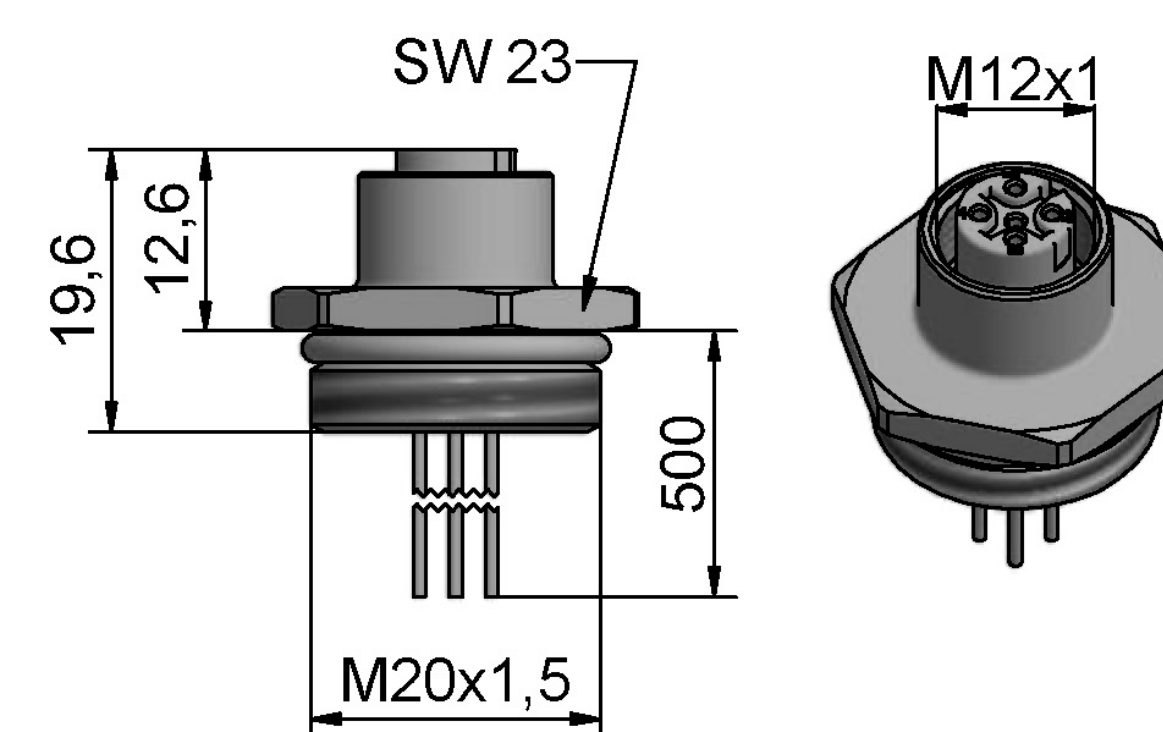

M12 Insert socket
4 terminals

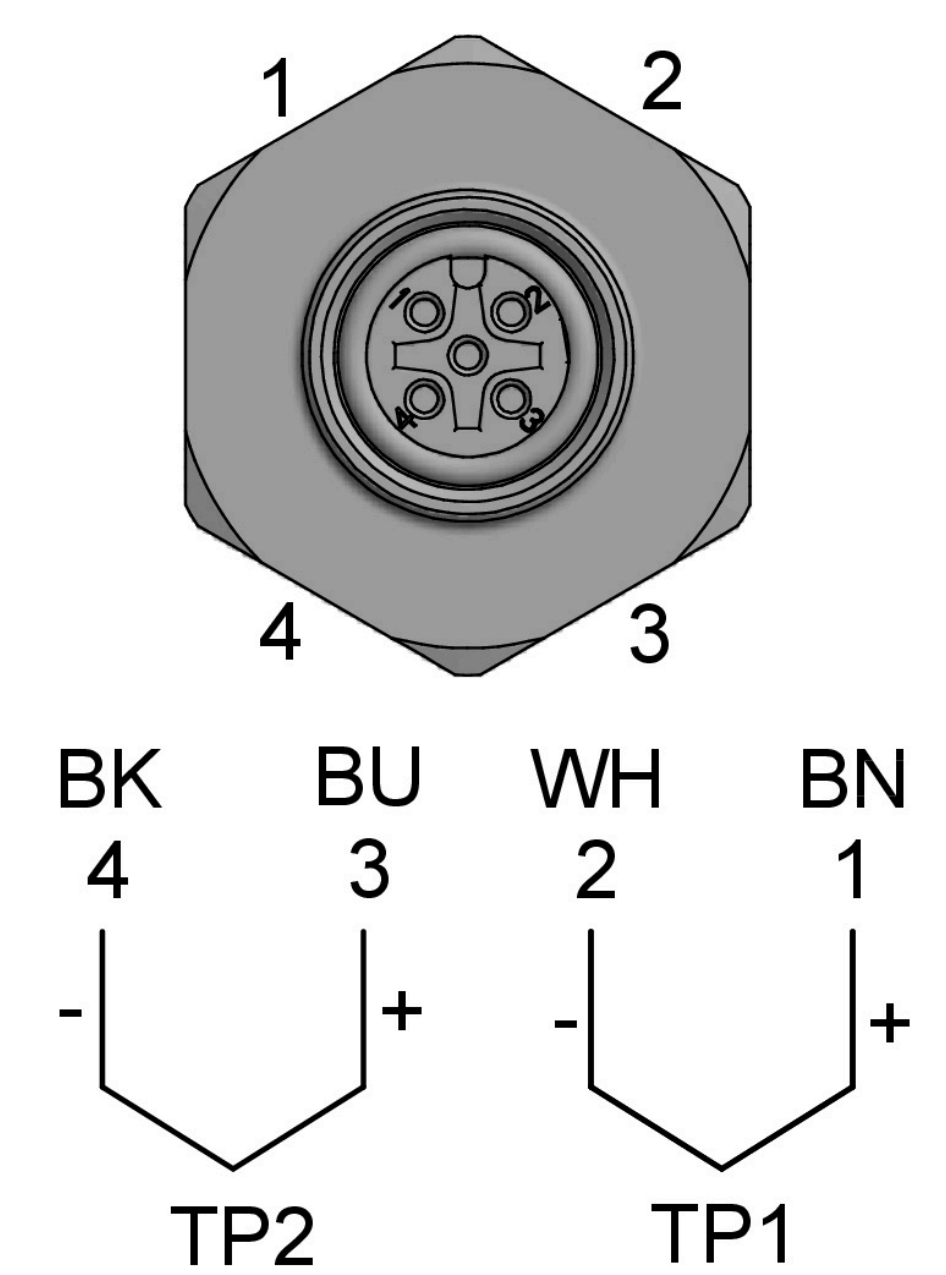

M12 Insert socket
2 thermocouples